

REVISIONS			
REV.	DESCRIPTION	DATE	BY
A	INITIAL R ELEASE	8/7/2017	KS
B	DECREASE THE TOLERANCE ON LOLE LOCATION	6/13/2019	KC

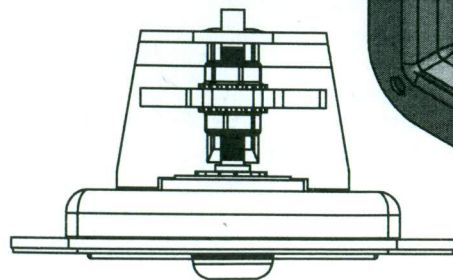
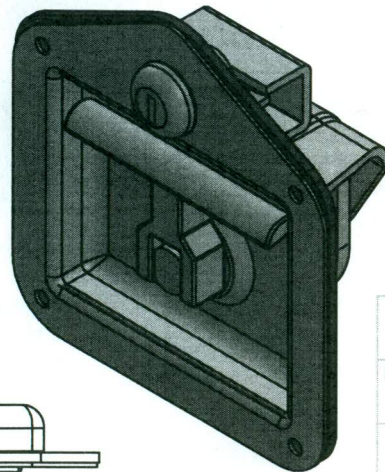
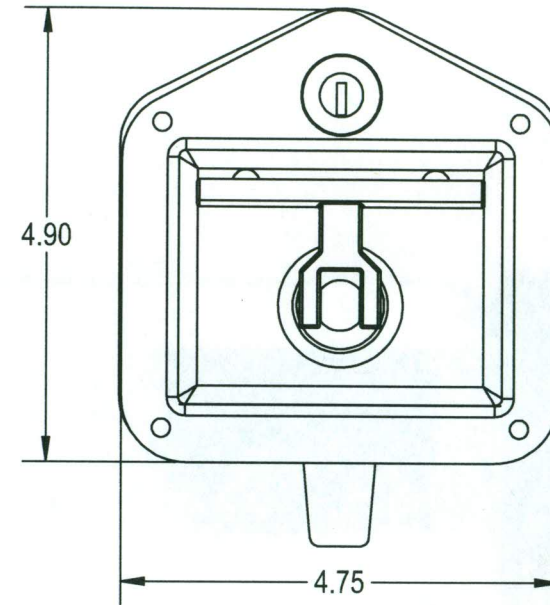
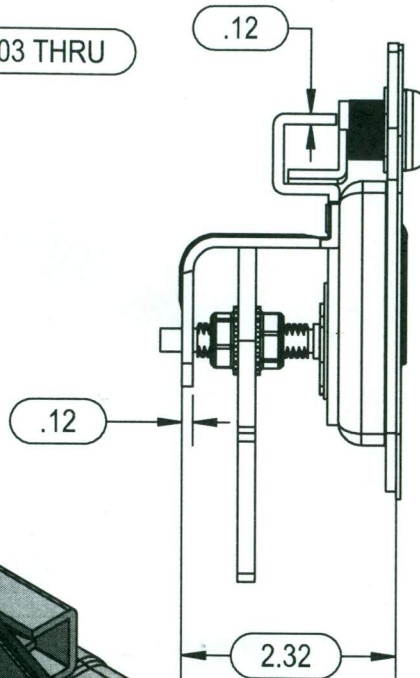
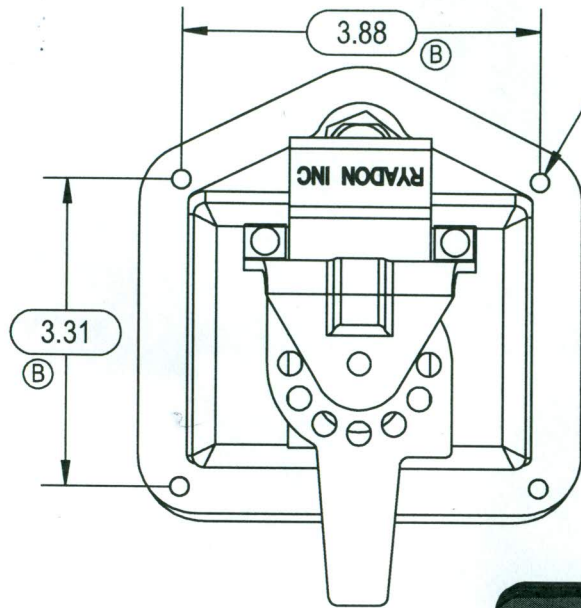

NOTES:

1. DIMENSIONS APPLY AFTER FINISH.
2. DO NOT SCALE DRAWING.
3. BREAK ALL SHARP EDGES AND REMOVE ALL BURRS.
4. MUST HAVE NO SCRATCHES, DINGS, DENTS OR SURFACE IMPERFECTIONS OTHER THAN SURFACE FINISH REQUIREMENTS.
5. CRITICAL DIMENSIONS ARE INDICATED BY:
6. TO BE INSPECTED TO 2.5 AQL SAMPLING PLAN UNLESS OTHERWISE STATED.
7. ENSURE PACKAGING WILL PROVIDE ADEQUATE PROTECTION DURING TRANSPORT.
8. GEOMETRIC FEATURES NOT DIMENSIONED ARE CONTROLLED BY 3D MODEL.

PART NUMBER:

DRAWING:

MATERIAL: